

## G - SERIES PHOTODIODE

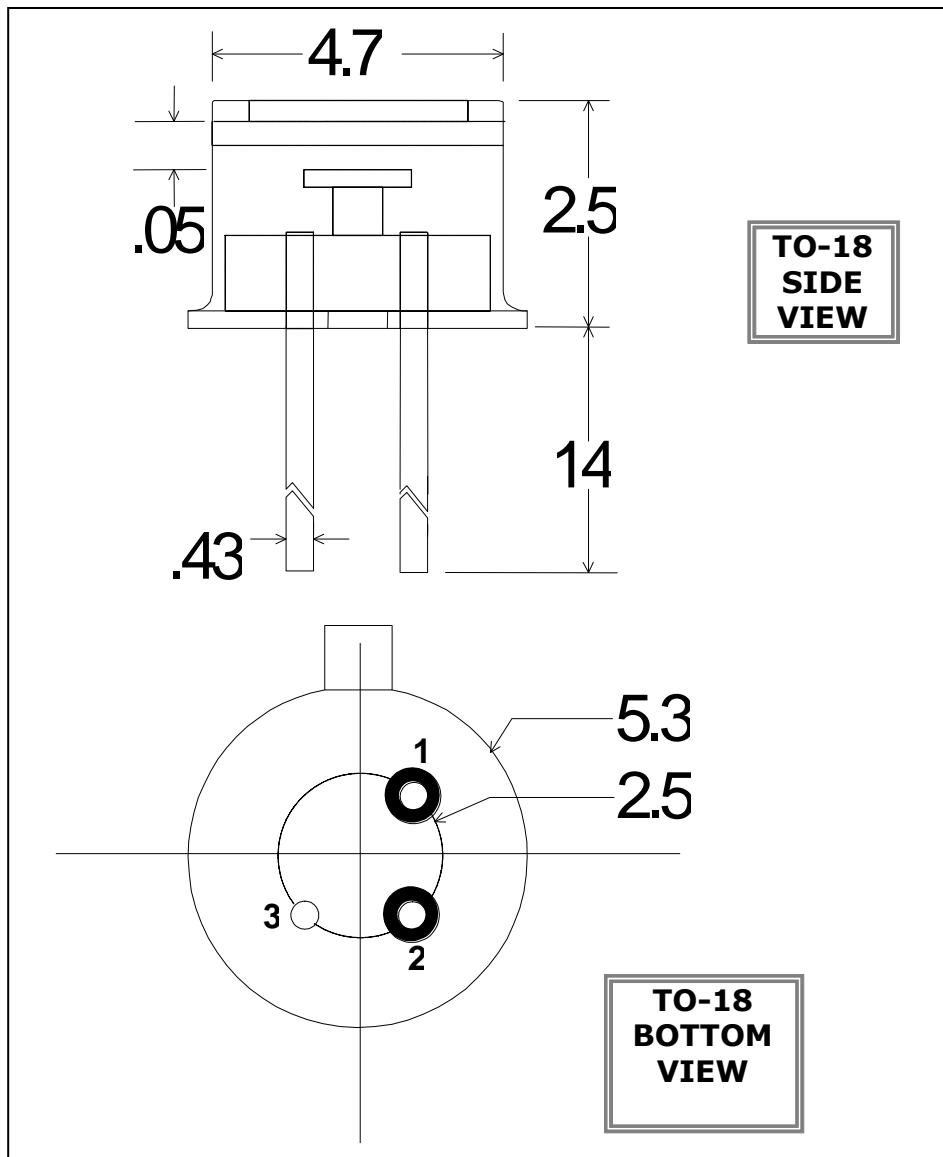

**Part No:** **G - 010**

**PIN OUT**

- 1 = ANODE
- 2 = CATHODE
- 3 = CASE

**Note:**

Dimensions in millimeters

### Application Note

**ELECTRO OPTICAL SYSTEMS** offers room temperature germanium photodiode detectors for operation in the 0.8 - 1.8  $\mu\text{m}$  spectral range. The units have state-of-the-art sensitivity and may be supported by accessories such as optical filters (longpass and bandpass), integral preamplifiers, and fiber optic connectors. These units find applications in industrial control systems, gas analyzers, thermal sensors, and general fiber optic test instrumentation.

### SPECIFICATIONS @ 23° C

Active Area	1 mm dia Germanium Photodiode
Operating Wavelength	0.8 - 1.8
Shunt Resistance ( $\Omega$ ) min	200k
Shunt Capacitance (pF), typ	1500
Responsivity (A/W)	0.90 @ 1.5 $\mu\text{m}$
NEP ( $\text{W}/\text{Hz}^{1/2}$ )	$< 3 \times 10^{-13}$ @ 1.5 $\mu\text{m}$

*RoHS Compliant*