

PBSE - SERIES PHOTOCONDUCTOR

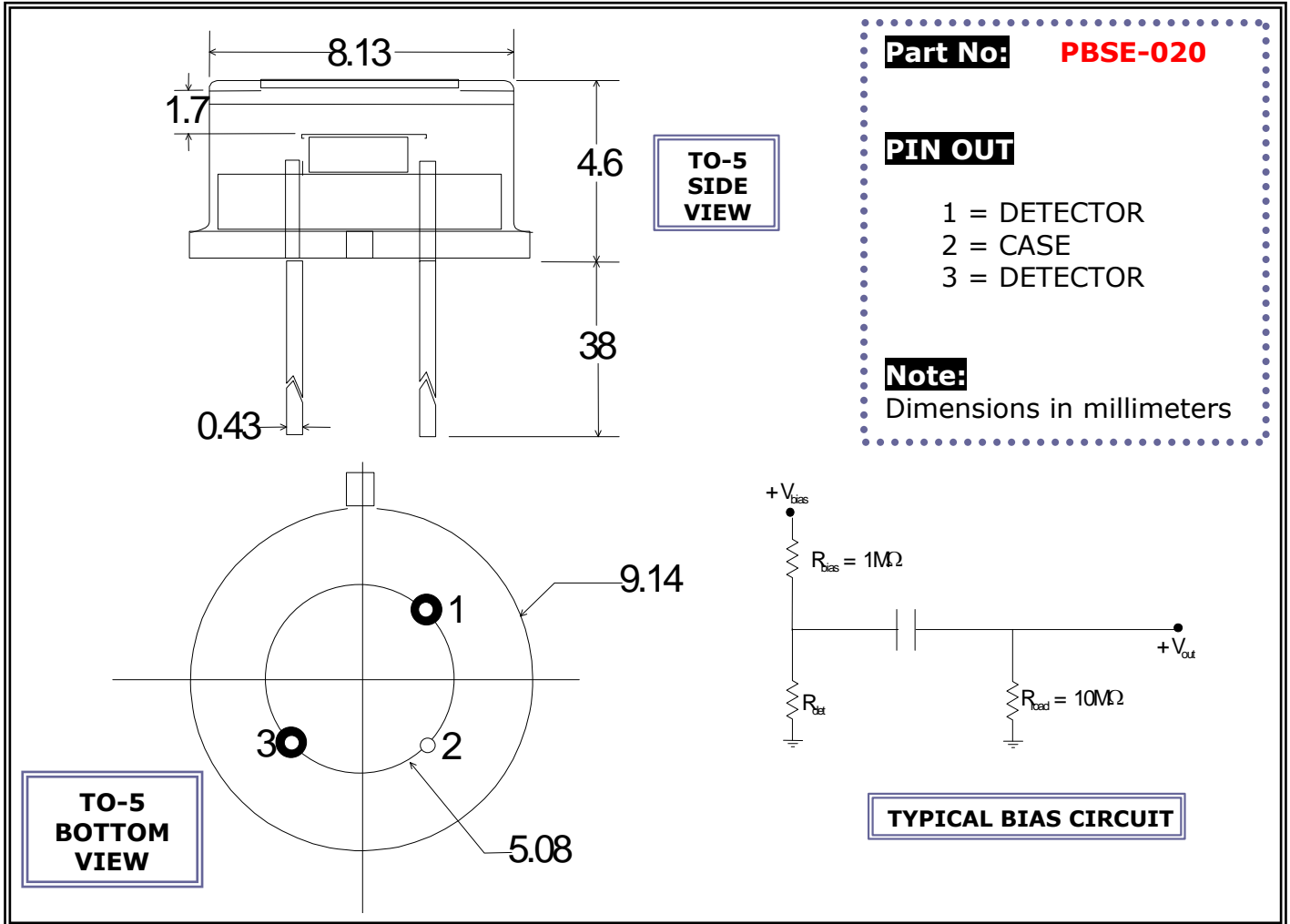

Application Note EOS offers room temperature and thermoelectrically cooled photoconductive detectors. The units have state-of-the-art sensitivity and may be supported by accessories such as optical filters (longpass and bandpass), integral preamplifiers, temperature controllers and infrared source assemblies. These units find applications in industrial control systems, gas analyzers, thermal sensors, and general infrared instrumentation.

SPECIFICATIONS

| | |
|---|-----------------------------|
| Active Area | 2mm x 2mm |
| Operating Temperature (°C) | 22 |
| Operating Wavelength | 1.0 – 4.5 microns |
| Dark Resistance (MΩ) | 0.5 nom |
| Time Constant (μs) | 15 typ |
| Voltage Bias (V) | 100 with 1M series resistor |
| Responsivity @ λ_p (V/W) | ≥ 4000 |
| $D^* @ \lambda_p$ (cm Hz ^{1/2} /W) | ≥ 5 x 10 ⁹ |